



Engineering Solutions

Bottom Entry-Snap In Wire Tie

Perfect for a smooth finished look and a secure, adjustable, reusable wire tie!

Features:

- Button head offers a finished, low profile look.
- Latch mechanism allows strap to be released and reinserted for multiple uses.
- Retaining tabs secure unused strap eliminating the need to cut off excess.
- Snaps into a 3/8" dia. hole in a .045" - .100" thick panel.
- Secures bundles up to 1.75" in diameter.
- Base rotates 360° inside hole for variable bundle positioning.

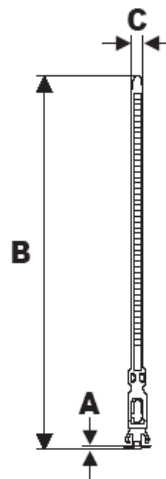
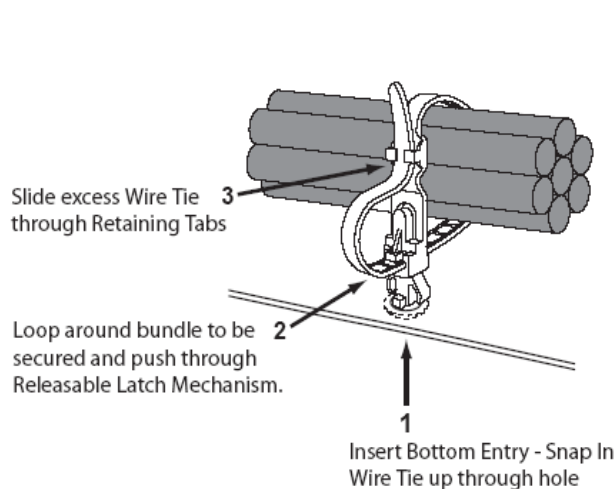

Material	Dimensions (in)		
	A	B	C
Nylon 6/6 Black	0.04	6.62	0.20

UL Flammability Rating = V2 Rating

**Latch Retention Grip Force 60 pounds
Dry as Molded***

*Users should conduct their own tests under specific actual conditions to determine the suitability for specific applications.

Atlanta | St. Louis | Chicago | Toronto

800.888.3326

www.efc-intl.com